

## FLOOR LAYING INSTRUCTIONS

### AMARON CHEVRON

#### NOTICE!

In order to eliminate colour discrepancies, during a given investment, it is recommended to use panels from a single production batch for installation. Before the installation, it is absolutely necessary to check the production batch, whose number can be found on each packaging.

#### NOTICE!

Before the installation, the panels must be carefully checked for material defects, especially decorative surface defects, mechanical damage of locks as well as colour or gloss discrepancies.

The variety and frequency of structures, wooden rings and knots, the presence of whitened wooden rings or cracks are elements of the design and do not constitute product defects. The installation of panels is regarded as the product acceptance and no damage and/or colour discrepancies as well as design varieties listed above can be the grounds for any subsequent claims regarding the product.

It is recommended that the panels be sorted according to the designs and shades before they are laid, and then the panels must be installed alternately in order to obtain the satisfactory uniform effect of variety in the room area. The panels should always be laid towards the main light source in order to obtain the best possible visual effect.

The open packaging must be used immediately (see-> PREPARATION, section No. 10)

# ASSEMBLY



## PREPARATION:

temperature: 18-30°C



humidity: 40-65%

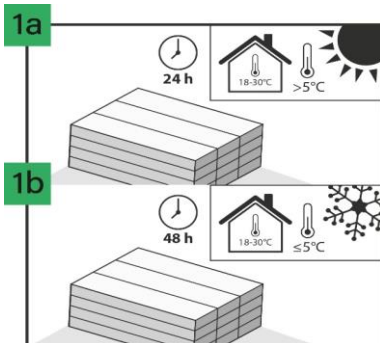

In the case of temperatures  $>5^{\circ}\text{C}$  during transport, the acclimatization time in a room with a temperature of  $18-30^{\circ}\text{C}$  should be 24 hours (in the room where they will be installed). And in the case of a temperature  $\leq 5^{\circ}\text{C}$  during transport, the acclimatization time in a room with a temperature of  $18-30^{\circ}\text{C}$  should be 48 hours.

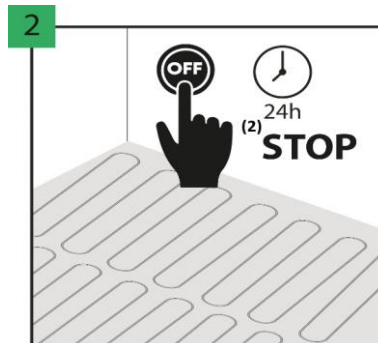

Turn off the underfloor heating for 24 hours before installation.

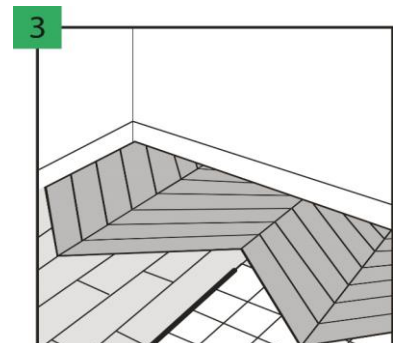

The type of base surface, its quality and preparation, especially unevenness, have a decisive impact on the final result. The panels are suitable for installation on cement and anhydrite floors, self-levelling screeds, on ceramic tiles, glued parquet, glued PVC carpets and linoleum and floors made of OSB or plywood with no deflection and moisture content in the wood below 10%. Installation on floating floors such as layered boards and laminate panels is permitted, provided that an underlay with  $\text{CS} = 200\text{kPa}$  and a vapour barrier with  $\text{SD} > 75\text{m}$  has been properly laid underneath. Do not lay the panels directly over carpet or other soft floor coverings. Before installation, the base surface or floor covering must always be lined with the acoustic and levelling underlay indicated by the guarantor. Failure to lay the underlay or laying the wrong underlay will result in a loss of guarantee and a high risk of damage to the panels themselves.

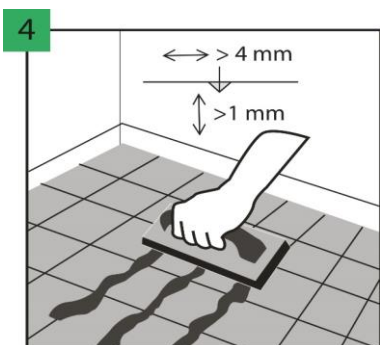

When installed on a tiled surface, tile joints with a gap wider than 4 mm and deeper than 1 mm should be filled with a durable joint filler, such as resin grout. Installation on tiles with joints up to 5 mm wide and 1 mm deep without joint levelling is permitted, provided Multiprotect Super Hardlay or Vinclic Super Solid underlay is used.

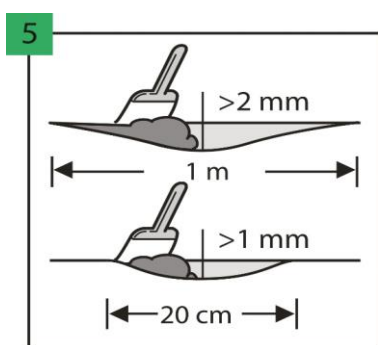

Make sure the substrate is completely flat. All substrate irregularities exceeding 1 mm over a length of 20 cm or 2 mm over a length of 1 m must be levelled.

# ASSEMBLY



## PREPARATION:

temperature: 18-30°C



humidity: 40-65%

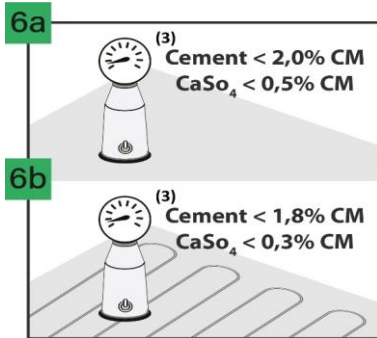

In the case of the cement grout, the moisture content in the substrate must be lower than 2.0%, and in the case of the anhydrite grout, it must be lower than 0.5%. In the case of installation with the underfloor heating, the abovementioned values must be 1.8% and 0.3% respectively.

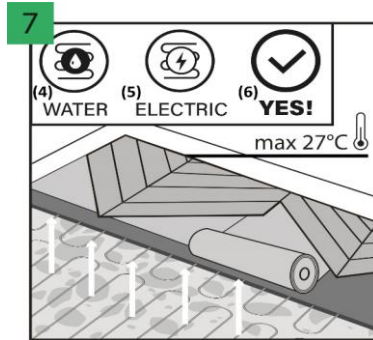

The floor panels can be used on a surface with underfloor heating, provided that a maximum floor surface temperature of 27°C is maintained. The underfloor heating should be switched off 24 hours before installation, and once the panels are laid, wait another 24 hours and gradually switch on the underfloor heating (5°C per day). It is permitted to install the floor over underfloor water heating or underfloor electric heating (sunk into the subfloor) guaranteeing the above indicated temperature ranges. Installation directly on an electric heating mat is not recommended.

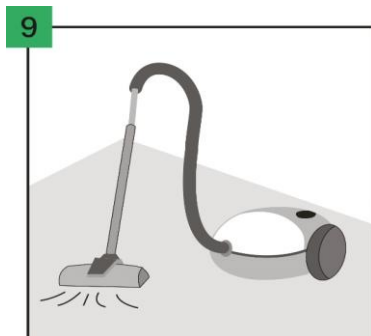
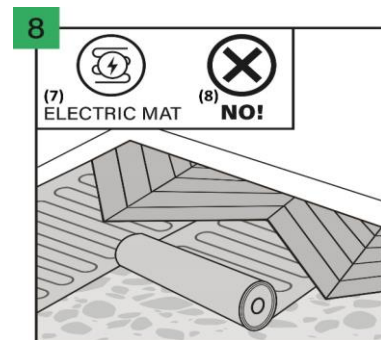

Ensure that the surface is dry, flat, stable and free of grease and chemicals. Protruding bumps should be scraped and removed. Before installation, the surface should be thoroughly swept and vacuumed, removing all dirt. It is necessary to repair more serious surface imperfections and large cracks.

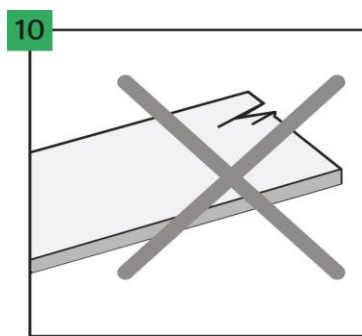

Before and during installation, all panels should be inspected in optimal lighting conditions. Do not install defective panels.

# ASSEMBLY



## PANEL LAYING:

temperature: 18-30°C



humidity: 40-65%



subfloor min. 15°C

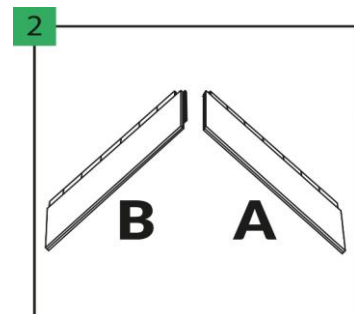
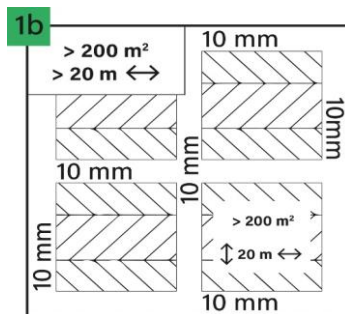
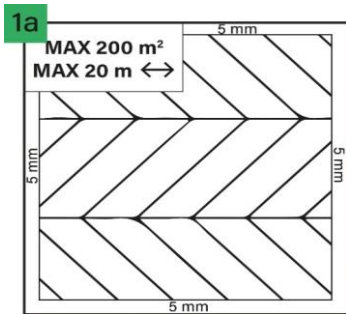

Leave 5 mm expansion joints at the walls. The maximum area that can be laid without additional expansion joints is 200 m<sup>2</sup>. Above this area, an additional expansion joint should be used and all expansion joints should be increased to 10 mm. The maximum length of floor surface in one direction that can be laid without additional expansion joints is 20 m. Above this length, additional expansion joints must be used and all expansion joints must be increased to 10 mm.

Each package contains two types of panels: A and B. The individual panels are labelled A or B on the bottom for easier distinction. Parts A and B should be sorted separately before installation. It is very important to make sure during installation that panels A and B are installed in the correct positions - rows (see -> panel installation, point no. 4-9).

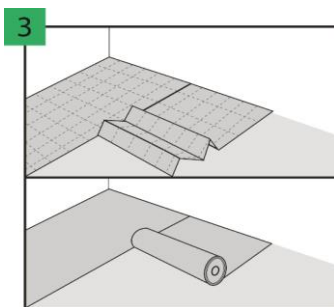

Ensure that the surface is properly prepared. Then lay an underlay of Arbiton, Afirmax or Ewifoam brand, which are designed for the installation of rigid and LVT floors. Adjacent strips of underlay should be tightly fitted and joined together by overlapping or AluTape by Arbiton or Ewifoam, leaving no unnecessary spaces.

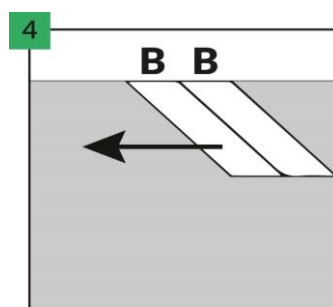

Lay the first row of panels B. It is easier to lay towards you but the panels can be installed in two directions.

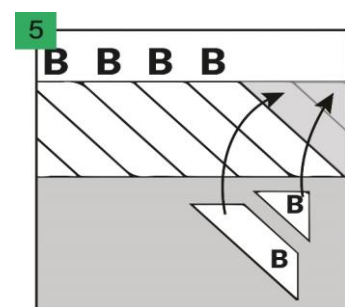

Fill in the missing spaces of the first row with trimmed panels B. It is important to remember to leave wall expansion joints.

# ASSEMBLY

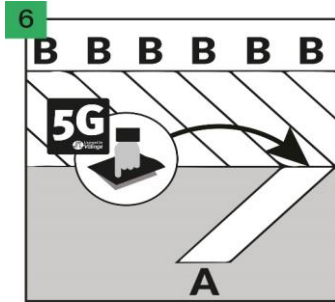

Fit (jam) panel A.

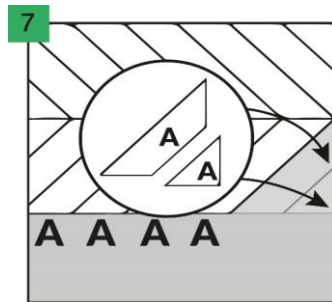

Fit (jam) the next panels A.  
It is easier to lay towards you, but the panels can be installed in two directions.  
Fill in the missing spaces of the second row with trimmed panels A.

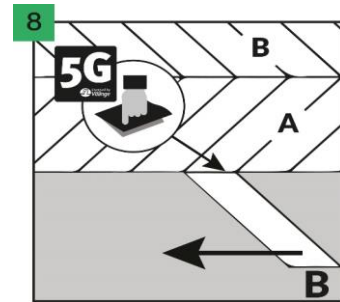

When proceeding to the next row, only use the panels B.

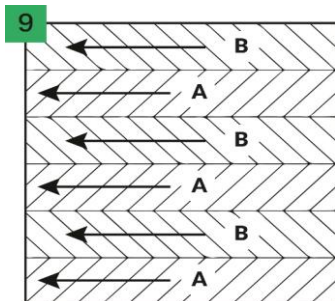

Alternate rows of panels: B, A, B, A,....  
It is recommended to lay the panels towards you, but the panels can be installed in two directions.

# ASSEMBLY



**FLOOR FINISH:**  
temperature: 18-30°C



humidity: 40-65%

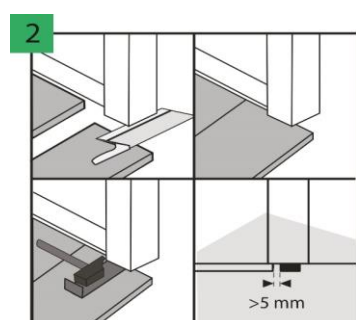
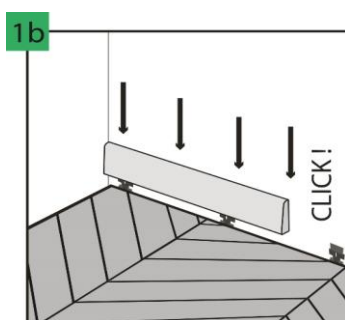
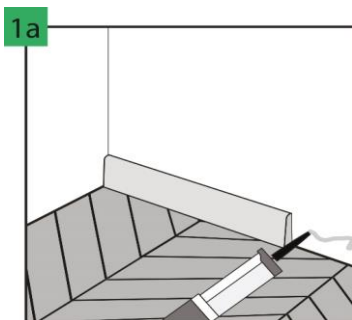

Expansion joints along the walls must be covered with a decorative strip, assembling it by means of glue or special clips. It is recommended to use the Arbiton strips dedicated to a given panel, which guarantee the excellent colour match and the coat resistant to scratching.

At the doors, it is recommended to undercut the profiles of door frames and leave free space over the installed panel so as not to limit its possible movement.

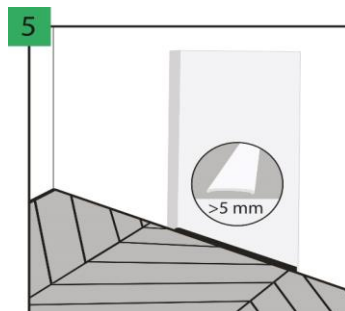
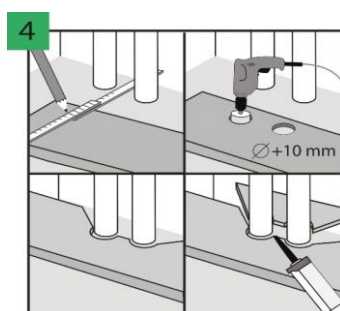
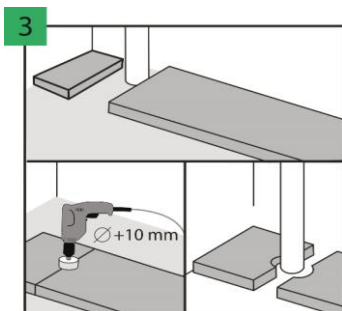

In the case of vertical pipes embedded in the substrate, leave free space around the pipes. Holes for the pipes must be drilled with a drill bit with a diameter that is bigger than the pipe diameter by 5 mm.

Act similarly in the case of a bigger number heating system pipes. The cut panel elements must be joined with the assembly adhesive for plastic elements.

In the following cases, it is recommended to use a 5 mm expansion joint in the doorway between the rooms to compensate for tension: irregular shape of the floor surface in adjacent rooms or the use of underfloor heating in only one of the connected rooms, or if there is underfloor heating in both rooms but with individual temperature control. For areas greater than 200 m<sup>2</sup> or longer than 20 m, the expansion joints should be increased to 10 mm.

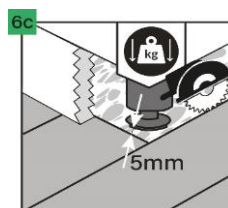
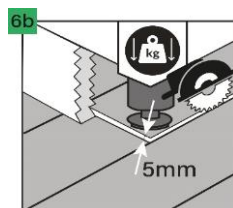
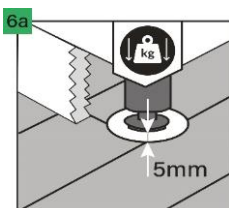

For any heavy items placed on the floor (such as kitchen units, kitchen islands, built-in wardrobes and other furniture permanently attached to the wall), leave 5 mm expansion joints around them.

We recommend the following ways of preserving expansion joints:

6a. Cutting a hole in the floor "for the feet" enlarged by 5 mm on each side so as to preserve the expansion joints

6b. Cutting the floor with a saw and making expansion joints of 5 mm each along the furniture construction

6c. Finish laying the floor with sufficient distance (5 mm on each side) from the heavy object

# ASSEMBLY



## USE AND MAINTENANCE:

temperature: 18-30°C



humidity: 40-65%

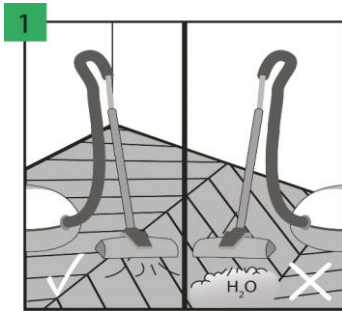

The Arbiton floor may be cleaned with a vacuum cleaner, however, it is prohibited to use steam cleaning devices.

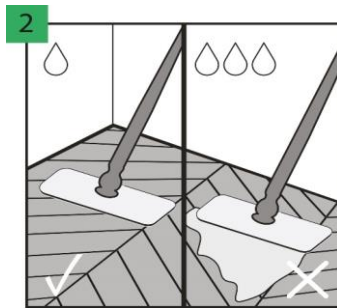

The Arbiton floor can be cleaned with a damp or wet mop.

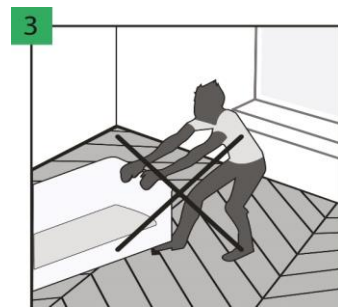

The movement of heavy objects along the floor is not allowed. They must be moved only after they are lifted.

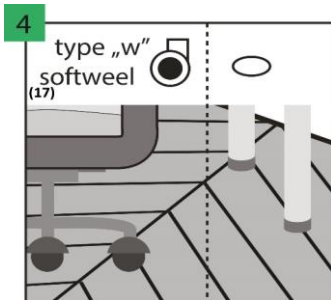

Used office chairs with W-type castors, protecting the floor additionally by means of the protective net. The furniture legs must be provided with protective pads which provide protection against scratching, e.g. made of felt.

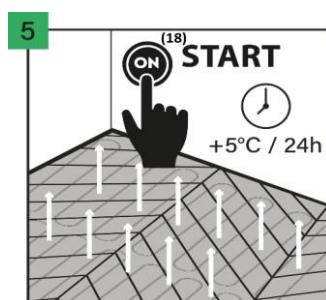

After laying the floor and waiting 24 hours, the underfloor heating can be switched on, bearing in mind the gradual increase in temperature (5°C per day).  
NOTE! Please remember that the maximum floor surface temperature is 27°C.